



NRJ1-18000-86

Singal Channel, DC~18GHz, 86Smm

- | | |
|-------------------------------|--|
| Features: | Applications: |
| * Low VSWR | * High Speed Digital Signal Transmission |
| * Low VSWR Flatness | * Analog Signal Transmission |
| * Low Insertion Loss Flatness | |

Electrical (Rotary Joint)

Frequency:	DC~18GHz
VSWR:	1.4 max.
VSWR Flatness:	0.05 max.
Insertion Loss:	0.3dB max.
Insertion Loss Flatness:	0.05 dBmax.
Phase Flatness:	1° max.
Average Power:	500W max. @1GHz 200W max. @6GHz 100W max. @12GHz 30W max. @18GHz
Peak Power:	3000W max.
IP Grade:	IP40 acc. EN 60529

Mechanical (Rotary Joint)

Connectors:	SMA female
Rotating Speed:	250RPM max.
Starting Torque:	0.5N.cm max.
Connector Axial Load:	±0.1N max.
Rotating Torque:	0.5 N.cm max.
Connector Radial Load:	±0.1N max.
Operation Life:	10M Cycles
Dielectric:	PTFE

Environmental

Temperature (Rotary Joint):	-55~+85°C
Temperature (Slip Ring):	-30~+80°C

Electrical (Slip Ring)

Voltage (Power/Signal):	0~440V/0~240V
Impedance of Dielectric (Power/Signal):	500/300MΩ min.
Lead Wire (Power):	AWG#17 Silver plated Teflon
Lead Wire (Signal):	AWG#22 Silver plated Teflon
Dielectric Resistance:	500V AC @50Hz, 60s
Electrical Noise:	0.01Ω max.
IP Grade:	IP51

Mechanical (Slip Ring)

Operation Life:	10M Cycles
Rotating Speed:	250RPM max.
Contact Material:	Gold
Housing:	Aluminum alloy
Torque:	0.01N.m @6 Channels + 0.05N.m

How To Order

NRJ1-18000-86-X-Y

X: Power Circuits

For example:

0610 - 6 circuits@10A

Y: Signal Circuits

For example:

06S - 6 circuits signal@2A

Customization is available upon request.

Color Code of Lead Wire

Ring	1	2	3	4	5	6	7	8	9	10	11	12
Color	BLK	BRN	RED	ORG	YEL	GRN	BLU	PUR	GRY	WHT	PINK	LGT BLU

Ring	13	14	15	16	17	18	19	20	21	22	23	24
Color	WHT/BLK	WHT/BRN	WHT/RED	WHT/ORG	WHT/YEL	WHT/GRN	WHT/BLU	WHT/PUR	WHT/GRY	BLK/RED	BLK/BRN	Transparet

Remark: "1" : the first wire from rotor side , NRJ1-18000-86-12S wire color sequence: BLK/BRN/RED/ORG/YEL/GRN/BLU/PUR/GRY/WHT/PINK/LGT BLU, 24 color wires asone group, if more than 24wires, repeat as sequence, use number tube to tell group 1#, 2#....

Outline Drawings

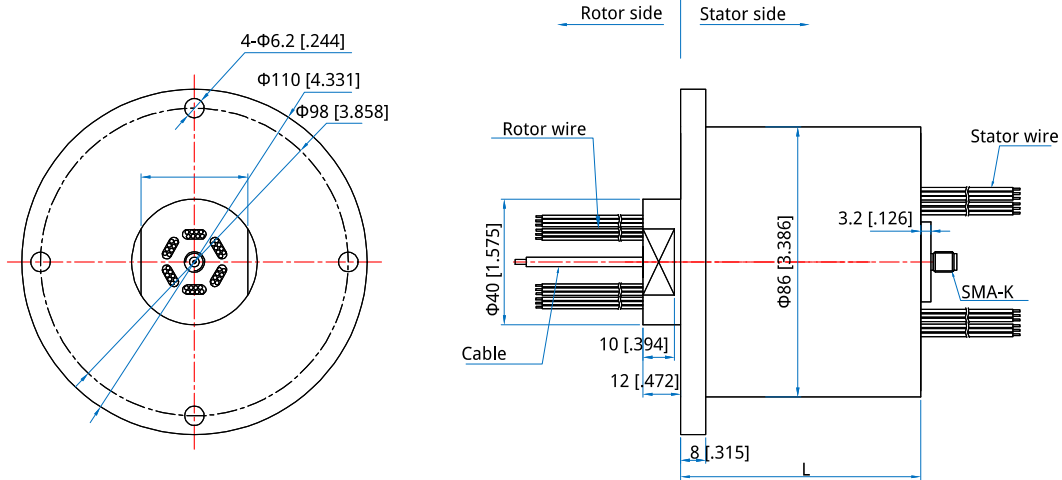

Unit: mm [in] Tolerance: $\pm 0.2\text{mm}$ [$\pm 0.008\text{in}$]

Standard Part Number List

Part Number	RF Channel	Frequency (GHz)	Circuits no. (10A)	Circuits no. (O- 2A)	Length L(mm/in)
NRJ1-18000-86-0610	1	DC~18	6	0	48 [1.89]
NRJ1-18000-86-06S	1	DC~18	0	6	48 [1.89]
NRJ1-18000-86-0610-06S	1	DC~18	6	6	72 [2.835]
NRJ1-18000-86-1210	1	DC~18	12	0	72 [2.835]
NRJ1-18000-86-12S	1	DC~18	0	12	72 [2.835]
NRJ1-18000-86-0610-12S	1	DC~18	6	12	96 [3.78]
NRJ1-18000-86-1810	1	DC~18	18	0	96 [3.78]
NRJ1-18000-86-18S	1	DC~18	0	18	96 [3.78]
NRJ1-18000-86-0610-18S	1	DC~18	6	18	120 [4.724]
NRJ1-18000-86-1210-12S	1	DC~18	12	12	120 [4.724]
NRJ1-18000-86-2410	1	DC~18	24	0	120 [4.724]
NRJ1-18000-86-24S	1	DC~18	0	24	120 [4.724]
NRJ1-18000-86-0610-30S	1	DC~18	6	30	168 [6.614]
NRJ1-18000-86-1210-24 S	1	DC~18	12	24	168 [6.614]
NRJ1-18000-86-3610	1	DC~18	36	0	168 [6.614]
NRJ1-18000-86-36S	1	DC~18	0	36	168 [6.614]
NRJ1-18000-86-0610-42S	1	DC~18	6	42	216 [8.504]
NRJ1-18000-86-1210-36S	1	DC~18	12	36	216 [8.504]
NRJ1-18000-86-2410-24S	1	DC~18	24	24	216 [8.504]
NRJ1-18000-86-4810	1	DC~18	48	0	216 [8.504]
NRJ1-18000-86-48S	1	DC~18	0	48	216 [8.504]
NRJ1-18000-86-2410-36S	1	DC~18	24	36	264 [10.394]
NRJ1-18000-86-6010	1	DC~18	60	0	264 [10.394]
NRJ1-18000-86-60S	1	DC~18	0	60	264 [10.394]
NRJ1-18000-86-2410-48S	1	DC~18	24	48	312 [12.283]



Rotary Joints

Part Number	RF Channel	Frequency (GHz)	Circuits no. (10A)	Circuits no. (0- 2A)	Length L(mm/in)
NRJ1-18000-86-7210	1	DC~ 18	72	0	312 [12.283]
NRJ1-18000-86-72S	1	DC~ 18	0	72	312 [12.283]
NRJ1-18000-86-96S	1	DC~ 18	0	96	360 [12.173]
NRJ1-18000-86-120S	1	DC~ 18	0	120	408 [16.063]

