

NMPS90

90°/GHz

- Features:
- * Low Insertion Loss
 - * High Power
 - * High Reliable

- Applications:
- * Laboratory Test
 - * Transmitter
 - * Instrumentation
 - * Wireless

Electrical

Frequency: DC~8GHz
 Impedance: 50Ω
 Average Power: 100W
 Peak Power^{*1}: 5KW

[1] Pulse width: 5us, duty cycle: 2%.

Frequency (GHz)	VSWR (max.)	Insertion Loss (dB, max.)	Phase Adjustment ^{*2} (°)
DC~1	1.2	0.5	0~90
DC~2	1.3	0.8	0~180
DC~3	1.4	1.2	0~270
DC~4	1.4	1.2	0~360
DC~6	1.5	1.4	0~540
DC~8	1.5	1.5	0~720

[2] Phase shift varies linearly corresponding to the frequency. For example, if the maximum phase shift is 360°@6GHz, the maximum phase shift is 180°@3GHz.

Mechanical

Size^{*3}: 236*76*30.5mm
 9.291*2.992*1.201in
 Size^{*4}: 241*76*50.5mm
 9.488*2.992*1.988in

Weight: 550g

RF Connectors: N Female, SMA Female
 Outer Conductor: Nickle Plated Brass
 Inner Conductor: Gold Plated Beryllium Bronze
 Housing Material: Aluminum

[3] Analog.
 [4] Digital.

Environmental

Operating Temperature: -10~+50°C
 Non-operating Temperature: -40~+70°C

Outline Drawings

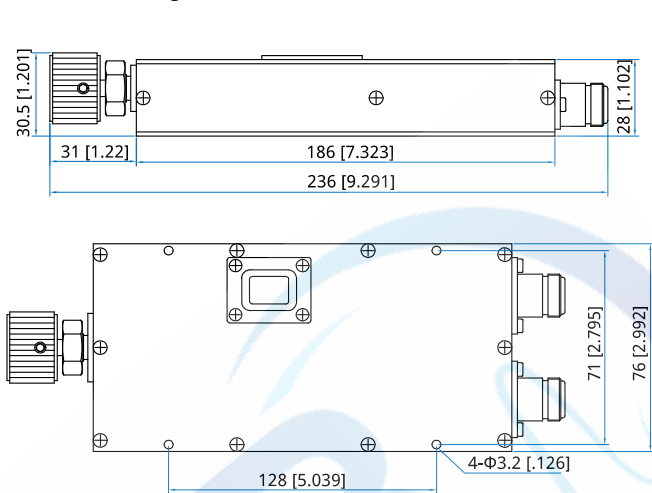

Outline A

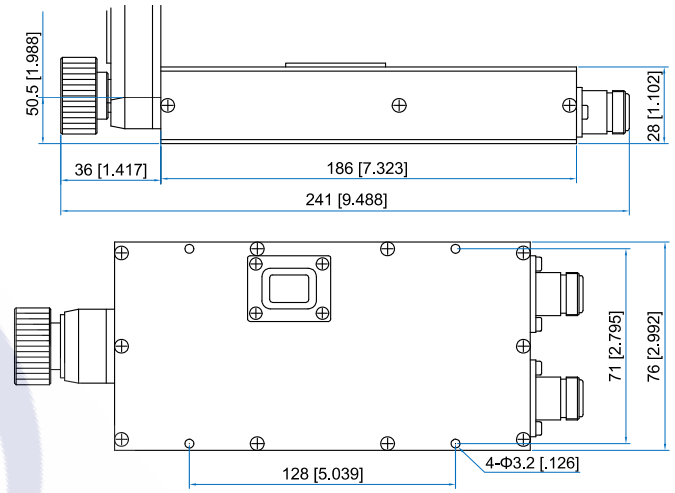

Outline B

Unit: mm [in]
 Tolerance: ±0.2mm [±0.008in]

How To Order

NMPS90-X-Y-Z
 X: Frequency in GHz
 Y: Connector type
 Z: Display

Examples:

To order a digital phase shifter, DC- 4GHz, N female to N female, specify NMPS90-4-N-D.

Customization is available upon request.

Connector naming rules:

S - SMA
 N - N

Display naming rules:

A - Analog (Outline A)
 D - Digital (Outline B)